



AVTECH ELECTROSYSTEMS LTD.

NANOSECOND WAVEFORM ELECTRONICS
SINCE 1975

P.O. BOX 265
OGDENSBURG, NY
U.S.A. 13669-0265

TEL: 888-670-8729 (USA & Canada) or +1-613-226-5772 (Intl)
FAX: 800-561-1970 (USA & Canada) or +1-613-226-2802 (Intl)

info@avtechpulse.com - <http://www.avtechpulse.com/>

BOX 5120, LCD MERIVALE
OTTAWA, ONTARIO
CANADA K2C 3H4

INSTRUCTIONS

MODEL AVO-6C-B
MODEL AVO-6C1-B

0 TO 5 Amp (0 to 250 Volts)
10 kHz LASER DIODE DRIVER
WITH IEEE 488.2 AND RS-232 CONTROL

SERIAL NUMBER: _____

WARRANTY

Avtech Electrosystems Ltd. warrants products of its manufacture to be free from defects in material and workmanship under conditions of normal use. If, within one year after delivery to the original owner, and after prepaid return by the original owner, this Avtech product is found to be defective, Avtech shall at its option repair or replace said defective item. This warranty does not apply to units which have been disassembled, modified or subjected to conditions exceeding the applicable specifications or ratings. This warranty is the extent of the obligation assumed by Avtech with respect to this product and no other warranty or guarantee is either expressed or implied.

TECHNICAL SUPPORT

Phone: 888-670-8729 (USA & Canada) or +1-613-226-5772 (Intl)

Fax: 800-561-1970 (USA & Canada) or +1-613-226-2802 (Intl)

E-mail: info@avtechpulse.com

World Wide Web: <http://www.avtechpulse.com>

TABLE OF CONTENTS

| | |
|---|-----------|
| WARRANTY | 2 |
| TECHNICAL SUPPORT | 2 |
| TABLE OF CONTENTS | 3 |
| INTRODUCTION | 5 |
| AVAILABLE OPTIONS | 6 |
| HIGH-VOLTAGE PRECAUTIONS | 7 |
| SPECIFICATIONS | 8 |
| EUROPEAN REGULATORY NOTES | 9 |
| EC DECLARATION OF CONFORMITY..... | 9 |
| DIRECTIVE 2002/95/EC (RoHS)..... | 9 |
| DIRECTIVE 2002/96/EC (WEEE)..... | 9 |
| INSTALLATION | 11 |
| VISUAL CHECK..... | 11 |
| POWER RATINGS..... | 11 |
| CONNECTION TO THE POWER SUPPLY..... | 11 |
| PROTECTION FROM ELECTRIC SHOCK..... | 12 |
| ENVIRONMENTAL CONDITIONS..... | 12 |
| LABVIEW DRIVERS..... | 13 |
| FUSES | 14 |
| AC FUSE REPLACEMENT..... | 14 |
| DC FUSE REPLACEMENT..... | 15 |
| FUSE RATINGS..... | 15 |
| FRONT PANEL CONTROLS | 16 |
| REAR PANEL CONTROLS | 18 |
| GENERAL INFORMATION | 20 |
| AMPLITUDE CONTROL..... | 20 |
| LENZ'S LAW AND INDUCTIVE VOLTAGE SPIKES..... | 21 |
| BASIC TEST ARRANGEMENT - WITHOUT OUTPUT MODULE..... | 21 |
| BASIC TEST ARRANGEMENT - WITH OUTPUT MODULE..... | 21 |
| BASIC PULSE CONTROL..... | 23 |
| TRIGGER MODES..... | 24 |
| GATING MODES..... | 25 |

| | |
|--|-----------|
| OPERATIONAL CHECK | 26 |
| PROGRAMMING YOUR PULSE GENERATOR | 30 |
| KEY PROGRAMMING COMMANDS..... | 30 |
| ALL PROGRAMMING COMMANDS..... | 31 |
| MECHANICAL INFORMATION | 33 |
| TOP COVER REMOVAL..... | 33 |
| RACK MOUNTING..... | 33 |
| ELECTROMAGNETIC INTERFERENCE..... | 33 |
| MAINTENANCE | 34 |
| REGULAR MAINTENANCE..... | 34 |
| CLEANING..... | 34 |
| WIRING DIAGRAMS | 35 |
| WIRING OF AC POWER..... | 35 |
| PCB 158M - LOW VOLTAGE POWER SUPPLY, 1/3..... | 36 |
| PCB 158M - LOW VOLTAGE POWER SUPPLY, 2/3..... | 37 |
| PCB 158M - LOW VOLTAGE POWER SUPPLY, 3/3..... | 38 |
| PCB 157C - HIGH VOLTAGE DISCHARGE BOARD..... | 39 |
| PCB 183A-S AND 183A-P CAPACITOR BANKS..... | 40 |
| PCB 156B – POLARITY SWITCHING CONTROL (-PN UNITS)..... | 41 |
| PCB 104D - KEYPAD / DISPLAY BOARD, 1/3..... | 42 |
| PCB 104D - KEYPAD / DISPLAY BOARD, 2/3..... | 43 |
| PCB 104D - KEYPAD / DISPLAY BOARD, 3/3..... | 44 |
| MAIN WIRING (-P UNITS)..... | 45 |
| MAIN WIRING (-PN UNITS)..... | 46 |
| PERFORMANCE CHECK SHEET | 47 |

INTRODUCTION

The AVO-6C-B is a high performance, GPIB and RS232-equipped instrument capable of generating 0 to 5.0 A at repetition rates up to 10 kHz. The pulse width is variable from 50 ns to 5 us, and the duty cycle may be as high as 1%. Rise and fall times are fixed at less than 10 ns. The AVO-6C-B includes an internal trigger source, but it can also be triggered or gated by an external source. A front-panel pushbutton can also be used to trigger the instrument.

The Model AVO-6C1-B variant has an extended pulse width range (50 us maximum, compared to 5 us for the standard AVO-6C-B). The AVO-6C1-B is not available with the -OS option. In all other respects, they are identical.

The AVO-6C-B features front panel keyboard and adjust knob control of the output pulse parameters along with a four line by 40-character backlit LCD display of the output amplitude, pulse width, pulse repetition frequency, and delay. The instrument includes memory to store up to four complete instrument setups. The operator may use the front panel or the computer interface to store a complete “snapshot” of all key instrument settings, and recall this setup at a later time.

The instrument is protected against overload conditions by an automatic control circuit. An internal power supply monitor removes the power to the output stage for five seconds if an average power overload exists. After that time, the unit operates normally for one second, and if the overload condition persists, the power is cut again. This cycle repeats until the overload is removed.

The AVO-6C-B consists of two parts, the mainframe and the output module. The mainframe is a voltage pulser, which generates 0 to +250V (V_{OUT}). The output module contains a 49Ω series resistance. The diode load is connected in series with this resistance, so that the current through the diode is normally given by:

$$I_{DIODE} = (V_{OUT} - V_{DIODE}) / 49\Omega$$

where V_{DIODE} is the voltage drop across the diode. An additional resistance (R_{SENSE}) can be placed in series with the load, for current monitoring purposes. In this case, the diode current is given by:

$$I_{DIODE} = (V_{OUT} - V_{DIODE}) / (49\Omega + R_{SENSE})$$

Alternatively, a fast current probe may be used to monitor the current waveform. Factory testing is conducted using a Tektronix CT2 or Pearson 2878 current transformer. (This technique tends to introduce less waveform distortion than the sensing resistor method.)

This instrument is intended for use in research, development, test and calibration laboratories by qualified personnel.

AVAILABLE OPTIONS

The AVO-6C-B is available with several options:

-EA Option: the amplitude can be controlled by an externally generated 0 to +10V analog control voltage.

-M Option: a monitor output is provided.

-OS Option: an externally generated DC offset can be added to the output. (Not available for the AVO-6C1-B.)

-R5 Option: This is the optional rack-mounting kit. The R5 rack-mount kit may also be ordered separately.

-S Option: Diode socket mounting option. Customer must supply socket specifications.

-TNT Option: Adds a rear-panel Ethernet connector, providing Telnet-based remote control from a network.

HIGH-VOLTAGE PRECAUTIONS

 **CAUTION:** This instrument provides output voltages as high as 250 Volts under normal operating conditions, and generates > 250V internally, so extreme caution must be employed when using this instrument. The instrument should only be used by individuals who are thoroughly skilled in high voltage laboratory techniques. The following precautions should always be observed:

1. Keep exposed high-voltage wiring to an absolute minimum.
2. Wherever possible, use shielded connectors and cabling.
3. Connect and disconnect loads and cables only when the instrument is turned off.
4. Keep in mind that all cables, connectors, oscilloscope probes, and loads must have an appropriate voltage rating.

Do not attempt any repairs on the instrument, beyond the fuse replacement procedures described in this manual. Contact Avtech technical support (see page 2 for contact information) if the instrument requires servicing.

SPECIFICATIONS

| | | |
|-------------------------------------|--|------------------------|
| Model: | AVO-6C-B ¹ | AVO-6C1-B ¹ |
| Amplitude ^{2,3} : | 0 - 5 Amps | |
| Pulse width (FWHM): | 50 ns - 5 us | 50 ns - 50 us |
| Rise & fall time (20%-80%): | ≤ 10 ns | |
| Maximum PRF: | 10 kHz | |
| Duty cycle (max): | 1 % | |
| Polarity ⁴ : | Positive or negative or both (specify) | |
| Output impedance: | 50 Ohms | |
| DC offset or bias insertion: | Optional ⁵ Apply required DC bias current in the range of ± 100 mA to solder terminals on the output module. Not available on the AVO-6HF-B or AVO-6C1-B (50 us models). | |
| Propagation delay: | ≤ 150 ns (Ext trig in to pulse out) | |
| Jitter: | ≤ ± 100 ps ± 0.03% of sync delay (Ext trig in to pulse out) | |
| Trigger required: | External trigger mode: TTL-level pulse (LOW: 0V, HIGH: +3 to +5V), 50 ns or wider | |
| Sync delay: | 0 to ± 1 sec | |
| Sync output: | + 3 Volts, 100 ns, will drive 50 Ohm loads | |
| Gate input: | Synchronous or asynchronous, active high or low, switchable. Suppresses triggering when active. | |
| Monitor output: | Optional ⁶ . Provides an attenuated coincident replica of output current. | |
| GPIO, RS-232 control ² : | Standard on -B units. | |
| Telnet / Ethernet control: | Optional ⁷ . See http://www.avtechpulse.com/options/tnt for details. | |
| Output connectors, standard: | Solder terminals. | |
| Optional output device sockets: | The standard solder terminals can be replaced by a plug-in or screw-in socket. See http://www.avtechpulse.com/laser-bias/avx-s1 for examples. Contact Avtech (info@avtechpulse.com) with your special device mounting requirement. | |
| Connectors, other: | BNC | |
| Power requirements: | 100 - 240 Volts, 50 - 60 Hz | |
| Dimensions: (H x W x D) | Mainframe: 100mm x 430 mm x 375mm (3.9" x 17" x 14.8") Output module: 41 mm x 66 mm x 76 mm (1.6" x 2.6" x 3.0") | |
| Chassis material: | Cast aluminum frame and handles, blue vinyl on aluminum cover plates | |
| Mounting: | Any | |
| Temperature range: | +5°C to +40°C | |

1) -B suffix indicates IEEE-488.2 GPIO and RS-232 control of amplitude and frequency. See <http://www.avtechpulse.com/gpio/> for details.

2) For operation at amplitudes of less than 20% of full-scale, best results will be obtained by setting the amplitude near full-scale and using external attenuators on the output (between the mainframe and the output module).

3) For analog electronic control (0 to +10V) of amplitude suffix model number with -EA. Electronic control units also include standard front-panel controls.

4) Indicate desired polarity by suffixing model number with -P or -N (i.e. positive or negative) or -PN for dual polarity.

5) For DC offset option suffix model number with -OS. Not available for the model AVO-6C1-B.

6) For monitor option add suffix -M.

7) Add the suffix -TNT to the model number to specify the Telnet / Ethernet control option.

EUROPEAN REGULATORY NOTES

EC DECLARATION OF CONFORMITY

We Avtech Electrosystems Ltd.
P.O. Box 5120, LCD Merivale
Ottawa, Ontario
Canada K2C 3H4

declare that this pulse generator meets the intent of Directive 89/336/EEC for Electromagnetic Compatibility. Compliance pertains to the following specifications as listed in the official Journal of the European Communities:

EN 50081-1 Emission

EN 50082-1 Immunity

and that this pulse generator meets the intent of the Low Voltage Directive 72/23/EEC as amended by 93/68/EEC. Compliance pertains to the following specifications as listed in the official Journal of the European Communities:

EN 61010-1:2001 Safety requirements for electrical equipment for measurement, control, and laboratory use



DIRECTIVE 2002/95/EC (RoHS)

This instrument is exempt from Directive 2002/95/EC of the European Parliament and of the Council of 27 January 2003 on the Restriction of the use of certain Hazardous Substances (RoHS) in electrical and electronic equipment. Specifically, Avtech instruments are considered "Monitoring and control instruments" (Category 9) as defined in Annex 1A of Directive 2002/96/EC. The Directive 2002/95/EC only applies to Directive 2002/96/EC categories 1-7 and 10, as stated in the "Article 2 - Scope" section of Directive 2002/95/EC.

DIRECTIVE 2002/96/EC (WEEE)

European customers who have purchased this equipment directly from Avtech will have completed a "WEEE Responsibility Agreement" form, accepting responsibility for

WEEE compliance (as mandated in Directive 2002/96/EC of the European Union and local laws) on behalf of the customer, as provided for under Article 9 of Directive 2002/96/EC.

Customers who have purchased Avtech equipment through local representatives should consult with the representative to determine who has responsibility for WEEE compliance. Normally, such responsibilities will lie with the representative, unless other arrangements (under Article 9) have been made.

Requirements for WEEE compliance may include registration of products with local governments, reporting of recycling activities to local governments, and financing of recycling activities.

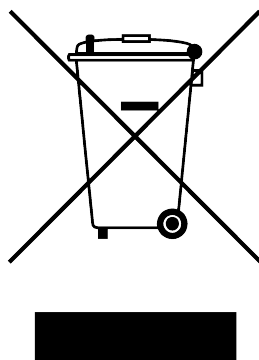

INSTALLATION

VISUAL CHECK

After unpacking the instrument, examine to ensure that it has not been damaged in shipment. Visually inspect all connectors, knobs, liquid crystal displays (LCDs), and the handles. Confirm that a power cord, a GPIB cable, and two instrumentation manuals (this manual and the “Programming Manual for -B Instruments”) are with the instrument. Confirm that an output module is supplied, with a length of coaxial cable to connect it to the mainframe. If the instrument has been damaged, file a claim immediately with the company that transported the instrument.

POWER RATINGS

This instrument is intended to operate from 100 - 240 V, 50 - 60 Hz.

The maximum power consumption is 74 Watts. Please see the “FUSES” section for information about the appropriate AC and DC fuses.

This instrument is an “Installation Category II” instrument, intended for operation from a normal single-phase supply.

CONNECTION TO THE POWER SUPPLY

An IEC-320 three-pronged recessed male socket is provided on the back panel for AC power connection to the instrument. One end of the detachable power cord that is supplied with the instrument plugs into this socket. The other end of the detachable power cord plugs into the local mains supply. Use only the cable supplied with the instrument. The mains supply must be earthed, and the cord used to connect the instrument to the mains supply must provide an earth connection. (The supplied cord does this.)

 Warning: Failure to use a grounded outlet may result in injury or death due to electric shock. This product uses a power cord with a ground connection. It must be connected to a properly grounded outlet. The instrument chassis is connected to the ground wire in the power cord.

The table below describes the power cord that is normally supplied with this instrument, depending on the destination region:

| Destination Region | Description | Manufacturer | Part Number |
|---------------------------------------|---|---|-------------|
| Continental Europe | European CEE 7/7 "Schuko" 230V, 50Hz | Qualtek (http://www.qualtekusa.com) | 319004-T01 |
| United Kingdom | BS 1363, 230V, 50Hz | Qualtek (http://www.qualtekusa.com) | 370001-E01 |
| Switzerland | SEV 1011, 2 30V, 50Hz | Volex (http://www.volex.com) | 2102H-C3-10 |
| Israel | SI 32, 220V, 50Hz | Volex (http://www.volex.com) | 2115H-C3-10 |
| North America, and all other areas | NEMA 5-15, 120V, 60 Hz | Qualtek (http://www.qualtekusa.com) | 312007-01 |

PROTECTION FROM ELECTRIC SHOCK

 Operators of this instrument must be protected from electric shock at all times. The owner must ensure that operators are prevented access and/or are insulated from every connection point. In some cases, connections must be exposed to potential human contact. Operators must be trained to protect themselves from the risk of electric shock. This instrument is intended for use by qualified personnel who recognize shock hazards and are familiar with safety precautions required to avoid possibly injury. In particular, operators should:

1. Keep exposed high-voltage wiring to an absolute minimum.
2. Wherever possible, use shielded connectors and cabling.
3. Connect and disconnect loads and cables only when the instrument is turned off.
4. Keep in mind that all cables, connectors, oscilloscope probes, and loads must have an appropriate voltage rating.
5. Do not attempt any repairs on the instrument, beyond the fuse replacement procedures described in this manual. Contact Avtech technical support (see page 2 for contact information) if the instrument requires servicing. Service is to be performed solely by qualified service personnel.

ENVIRONMENTAL CONDITIONS

This instrument is intended for use under the following conditions:

1. indoor use;
2. altitude up to 2 000 m;
3. temperature 5 °C to 40 °C;

4. maximum relative humidity 80 % for temperatures up to 31 °C decreasing linearly to 50 % relative humidity at 40 °C;
5. Mains supply voltage fluctuations up to ± 10 % of the nominal voltage;
6. no pollution or only dry, non-conductive pollution.

LABVIEW DRIVERS

A LabVIEW driver for this instrument is available for download on the Avtech web site, at <http://www.avtechpulse.com/labview>. A copy is also available in National Instruments' Instrument Driver Library at <http://www.natinst.com/>.

FUSES

This instrument contains four fuses. All are accessible from the rear-panel. Two protect the AC prime power input, and two protect the internal DC power supplies. The locations of the fuses on the rear panel are shown in the figure below:

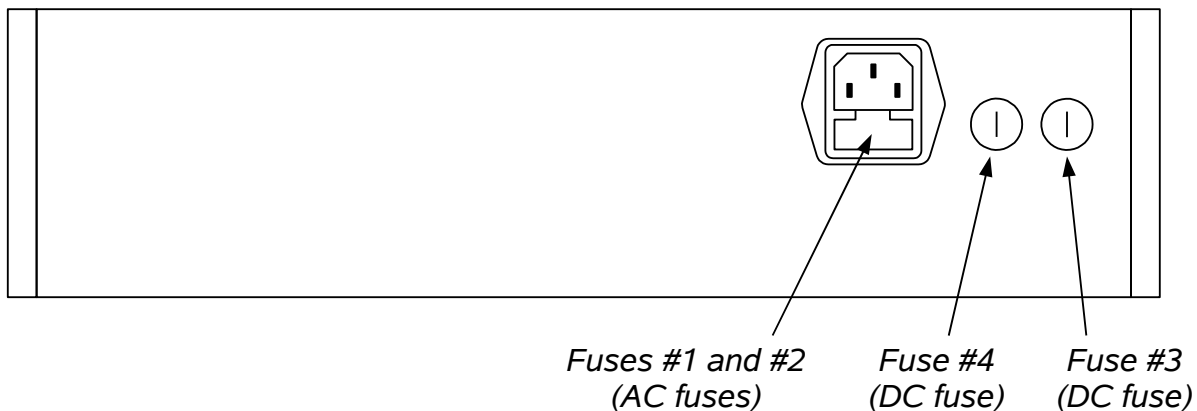

AC FUSE REPLACEMENT

To physically access the AC fuses, the power cord must be detached from the rear panel of the instrument. The fuse drawer may then be extracted using a small flat-head screwdriver, as shown below:

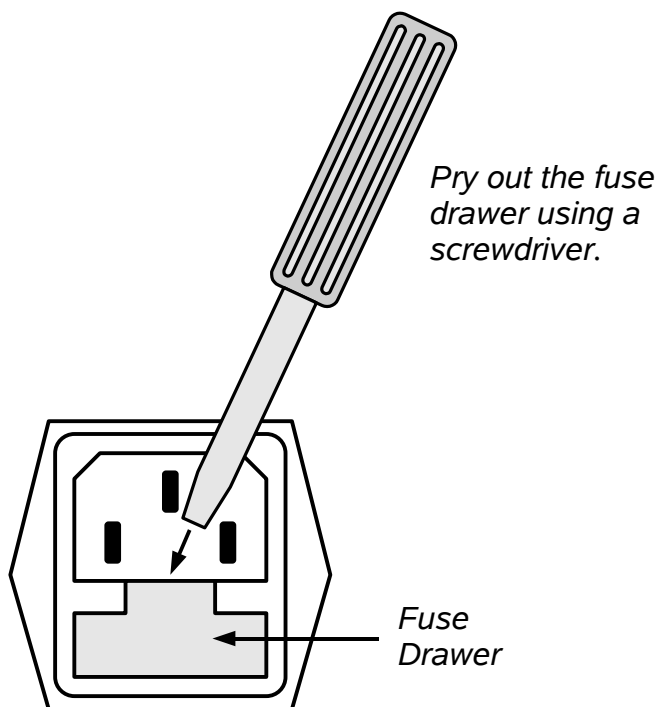

DC FUSE REPLACEMENT

The DC fuses may be replaced by inserting the tip of a flat-head screwdriver into the fuse holder slot, and rotating the slot counter-clockwise. The fuse and its carrier will then pop out.

FUSE RATINGS

The following table lists the required fuses:

| Fuses | Nominal Mains Voltage | Rating | Case Size | Recommended Replacement Part | |
|-------------|-----------------------|------------------------|-----------|------------------------------|-----------------------|
| | | | | Littelfuse Part Number | Digi-Key Stock Number |
| #1, #2 (AC) | 100-240V | 0.5A, 250V, Time-Delay | 5×20 mm | 0218.500HXP | F2416-ND |
| #3 (DC) | N/A | 1.6A, 250V, Time-Delay | 5×20 mm | 021801.6HXP | F2424-ND |
| #4 (DC) | N/A | 1.0A, 250V, Time-Delay | 5×20 mm | 0218001.HXP | F2419-ND |

The recommended fuse manufacturer is Littelfuse (<http://www.littelfuse.com>).

Replacement fuses may be easily obtained from Digi-Key (<http://www.digikey.com>) and other distributors.

FRONT PANEL CONTROLS

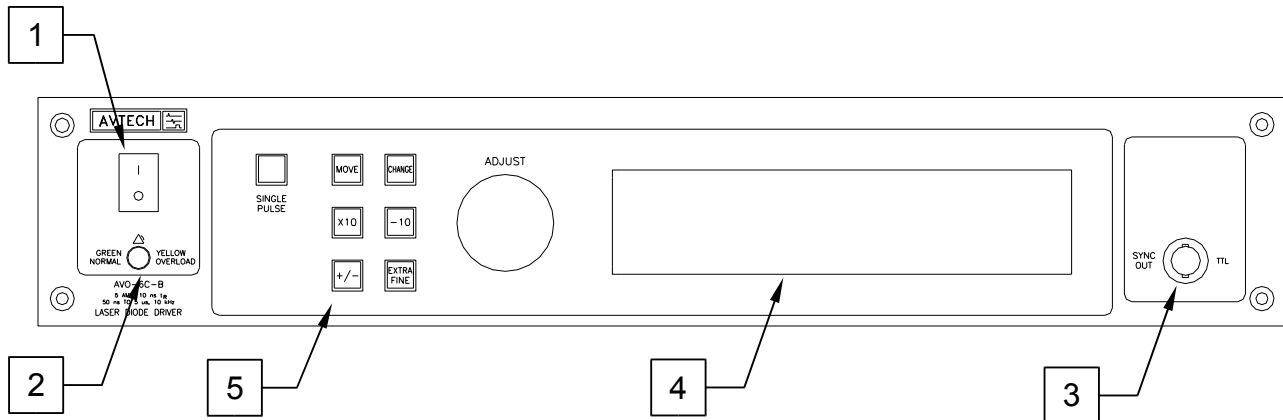

1. POWER Switch. This is the main power switch. When turning the instrument on, there may be a delay of several seconds before the instrument appears to respond.
2. OVERLOAD Indicator. When the instrument is powered, this indicator is normally green, indicating normal operation. If this indicator is yellow, an internal automatic overload protection circuit has been tripped. If the unit is overloaded (by operating at an exceedingly high duty cycle or by operating into a very low impedance), the protective circuit will disable the output of the instrument and turn the indicator light yellow. The light will stay yellow (i.e. output disabled) for about 5 seconds after which the instrument will attempt to re-enable the output (i.e. light green) for about 1 second. If the overload condition persists, the output will be disabled again (i.e. light yellow) for another 5 seconds. If the overload condition has been removed, the instrument will resume normal operation.

This overload indicator may flash yellow briefly at start-up. This is not a cause for concern.
3. SYNC OUT. This connector supplies a SYNC output that can be used to trigger other equipment, particularly oscilloscopes. This signal leads (or lags) the main output by a duration set by the "DELAY" controls and has an approximate amplitude of +3 Volts to $R_L > 1k\Omega$ with a pulse width of approximately 100 ns.
4. LIQUID CRYSTAL DISPLAY (LCD). This LCD is used in conjunction with the keypad to change the instrument settings. Normally, the main menu is displayed, which lists the key adjustable parameters and their current values. The "Programming Manual for -B Instruments" describes the menus and submenus in detail.

5. KEYPAD.

| Control Name | Function |
|--------------|---|
| MOVE | This moves the arrow pointer on the display. |
| CHANGE | This is used to enter the submenu, or to select the operating mode, pointed to by the arrow pointer. |
| ×10 | If one of the adjustable numeric parameters is displayed, this increases the setting by a factor of ten. |
| ÷10 | If one of the adjustable numeric parameters is displayed, this decreases the setting by a factor of ten. |
| +/- | If one of the adjustable numeric parameters is displayed, and this parameter can be both positive or negative, this changes the sign of the parameter. |
| EXTRA FINE | This changes the step size of the ADJUST knob. In the extra-fine mode, the step size is twenty times finer than in the normal mode. This button switches between the two step sizes. |
| ADJUST | This large knob adjusts the value of any displayed numeric adjustable values, such as frequency, pulse width, etc. The adjust step size is set by the "EXTRA FINE" button. When the main menu is displayed, this knob can be used to move the arrow pointer. |

REAR PANEL CONTROLS

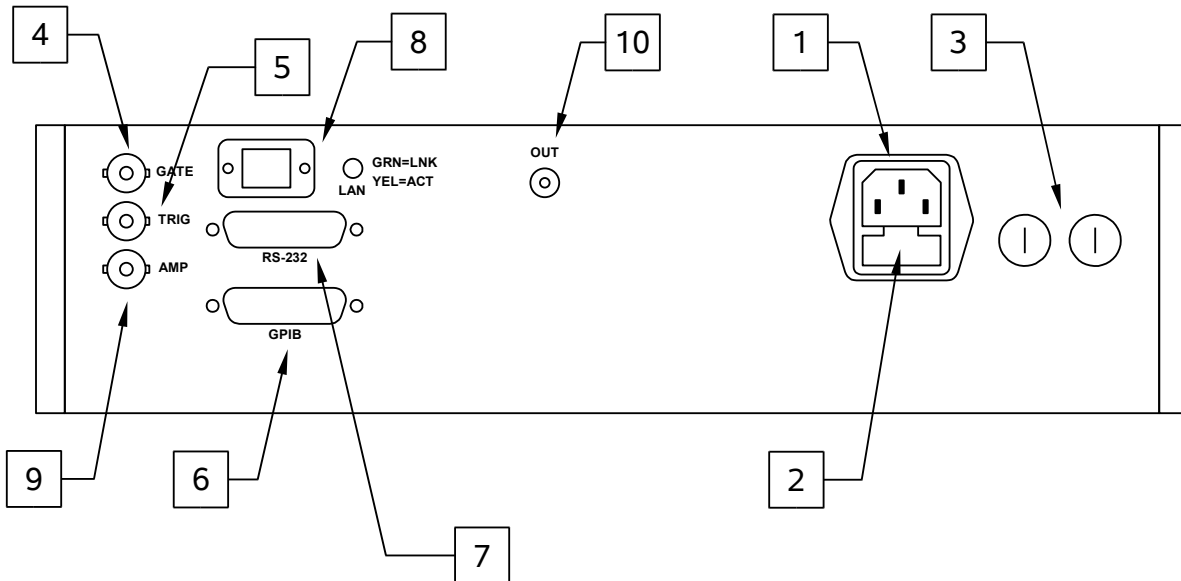

1. **AC POWER INPUT.** An IEC-320 C14 three-pronged recessed male socket is provided on the back panel for AC power connection to the instrument. One end of the detachable power cord that is supplied with the instrument plugs into this socket.
2. **AC FUSE DRAWER.** The two fuses that protect the AC input are located in this drawer. Please see the “FUSES” section of this manual for more information.
3. **DC FUSES.** These two fuses protect the internal DC power supplies. Please see the “FUSES” sections of this manual for more information.
4. **GATE.** This TTL-level (0 and +5V) logic input can be used to gate the triggering of the instrument. This input can be either active high or active low, depending on the front panel settings or programming commands. (The instrument triggers normally when this input is unconnected). When set to active high mode, this input is pulled-down to ground by a 1 k Ω resistor. When set to active low mode, this input is pulled-up to +5V by a 1 k Ω resistor.
5. **TRIG.** This TTL-level (0 and +5V) logic input can be used to trigger the instrument, if the instrument is set to triggering externally. The instrument triggers on the rising edge of this input. The input impedance of this input is 1 k Ω . (Depending on the length of cable attached to this input, and the source driving it, it may be desirable to add a coaxial 50 Ohm terminator to this input to provide a proper transmission line termination. The Pasternack (www.pasternack.com) PE6008-50 BNC feed-thru 50 Ohm terminator is suggested for this purpose.)

When triggering externally, the instrument can be set such that the output pulse width tracks the pulse width on this input, or the output pulse width can be set

independently.

6. GPIB Connector. A standard GPIB cable can be attached to this connector to allow the instrument to be computer-controlled. See the “Programming Manual for -B Instruments” for more details on GPIB control.
7. RS-232 Connector. A standard serial cable with a 25-pin male connector can be attached to this connector to allow the instrument to be computer-controlled. See the “Programming Manual for -B Instruments” for more details on RS-232 control.
8. LAN Connector and Indicator. (Optional feature. Present on -TNT units only.) The -TNT option "Internet-enables" Avtech pulse generators by adding this standard Ethernet port to the rear panel, in addition to the IEEE-488.2 GPIB and RS-232 ports normally found on "-B" units. Commands are sent using the standard Telnet protocol. The SCPI-compliant command set is the same as that used for GPIB and RS-232 control. The -TNT option uses the Dynamic Host Configuration Protocol (DHCP) to obtain its network address. A DHCP server must be present on the local network for the -TNT option to operate properly.
9. OS Connector. (Optional feature. Present on "-OS" units only.) The desired DC offset is applied to this connector. Internally, it is connected to the output centre conductor via a high quality RF inductor. Do not exceed $\pm 50\text{V}$, 250 mA. When not used, the OS input should be connected to ground.

or

AMP Connector. (Optional feature. Present on "-EA" units only.) The output amplitude can be set to track the voltage on this input. Zero Volts in corresponds to zero amplitude output, and +10V in corresponds to maximum amplitude out. This mode is activated by selecting "Ext Control" on the front-panel amplitude menu, or with the "source:voltage external" command.

10. OUT CONNECTOR. This SMA connector is connected to the output module, when the output module is used to drive a diode load. If the output module is not used, this output will generate up to 250V into a load impedance of 50Ω .

 Caution: Voltages as high as $\pm 250\text{V}$ may be present on the center conductor of this output connector. Avoid touching this conductor. Connect to this connector using standard coaxial cable, to ensure that the center conductor is not exposed.

GENERAL INFORMATION

AMPLITUDE CONTROL

The AVO-6C-B consists of two parts, the mainframe and the output module. The mainframe is a voltage pulser, which generates 0 to +250V (assuming that the model is a “-P” positive unit, or a dual-polarity model operating in the positive mode). The output module contains a 49Ω series resistance. The diode load is connected in series with this resistance, so that the current through the diode is normally given by:

$$I_{\text{DIODE}} = (V_{\text{OUT}} - V_{\text{DIODE}}) / 49\Omega$$

where V_{DIODE} is the voltage drop across the diode.

The functional equivalent circuit of the output module is shown below:

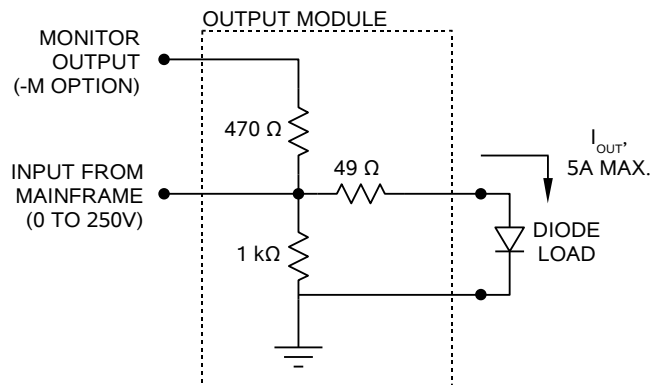

Output Module Functional Equivalent Circuit

(The equivalent circuit is shown for positive outputs. For “-N” instruments, and the negative output circuit of the dual-polarity “-PN” instruments, the polarities are negative and diodes are reversed in direction.)

On units with the -M option, a monitor output is provided, as shown above. When the monitor output is terminated with a 50 Ohm resistance, the monitor output provides an attenuated (approximately 20 dB) replica of the input signal to the output module.

An additional resistance (R_{SENSE}) can be placed in series with the diode load, for current monitoring purposes. In this case, the diode current is given by:

$$I_{\text{DIODE}} = (V_{\text{OUT}} - V_{\text{DIODE}}) / (49\Omega + R_{\text{SENSE}})$$

Alternatively, a fast current probe may be used to monitor the current waveform. Factory testing is conducted using a Tektronix CT2 or Pearson 2878 current

transformer. (This technique tends to introduce less waveform distortion than the sensing resistor method.)

LENZ'S LAW AND INDUCTIVE VOLTAGE SPIKES

This instrument is designed to pulse resistive and diode loads and will exhibit a large output spike when used to drive a load with significant inductance (as predicted by LENZ'S LAW). For this reason the load should be connected to the output using low inductance leads (as short as possible).

The voltage developed across an inductance L (in Henries), when the current is changing at a rate given by di_{LOAD} / dt (in Amps/sec), is: $V_{SPIKE} = L di_{LOAD} / dt$.

BASIC TEST ARRANGEMENT - WITHOUT OUTPUT MODULE

The AVO-6C-B can be tested initially without the supplied output module. If the output module is not used, the mainframe output generates 0 to +250 Volts (for -P units), or 0 to -250V (for -N units), into a 50 Ohm load, as illustrated below:

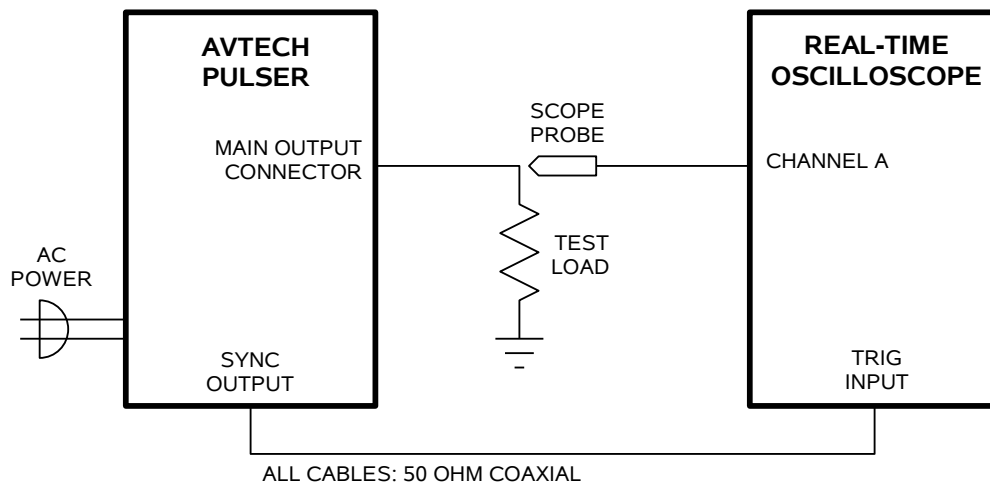

The load resistor must have a voltage rating of at least 250V, and a power rating of at least 12 Watts. It must also be low-inductance, or the waveform will become distorted and exhibit noticeable ringing.

BASIC TEST ARRANGEMENT - WITH OUTPUT MODULE

To fully test the instrument, and for normal operation, the output module must be connected as shown below:

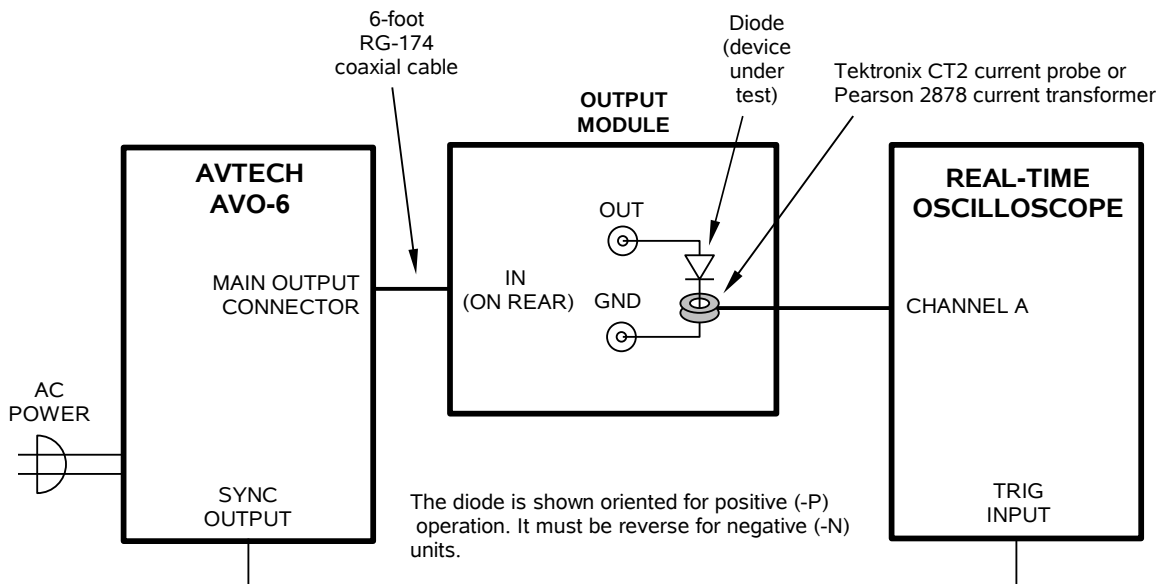

If a Tektronix CT2 current probe or Pearson 2878 current transformer is not available to measure the output current waveform, a 1 Ohm resistor may be used to sense the current instead. However, noticeable ringing and distortion may be appear on the waveform if this technique is used. (The use of a Tektronix CT2 current probe or Pearson 2878 current transformer is strongly recommended for this reason.) This alternative test arrangement is shown below:

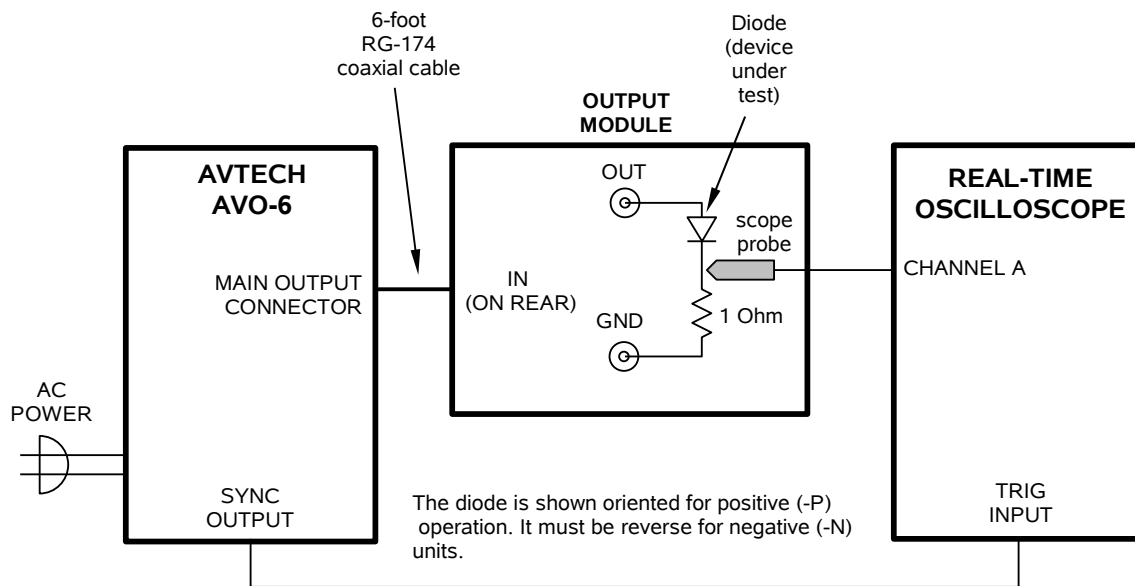

If the AVO-6C-B is operated at its maximum duty cycle, the worst-case power dissipation in the output module is $(250V \times 5A \times 1\%) = 12.5$ Watts. When operating near 1% duty cycle, the output module should be bolted to a heatsink, using the tapped screw holes on the bottom of the module.

BASIC PULSE CONTROL

This instrument can be triggered by its own internal clock or by an external TTL trigger signal. In either case, two output channels respond to the trigger: OUT and SYNC. The OUT channel is the signal that is applied to the load. Its amplitude and pulse width are variable. The SYNC pulse is a fixed-width TTL-level reference pulse used to trigger oscilloscopes or other measurement systems. When the delay is set to a positive value the SYNC pulse precedes the OUT pulse. When the delay is set to a negative value the SYNC pulse follows the OUT pulse.

These pulses are illustrated below, assuming internal triggering and a positive delay:

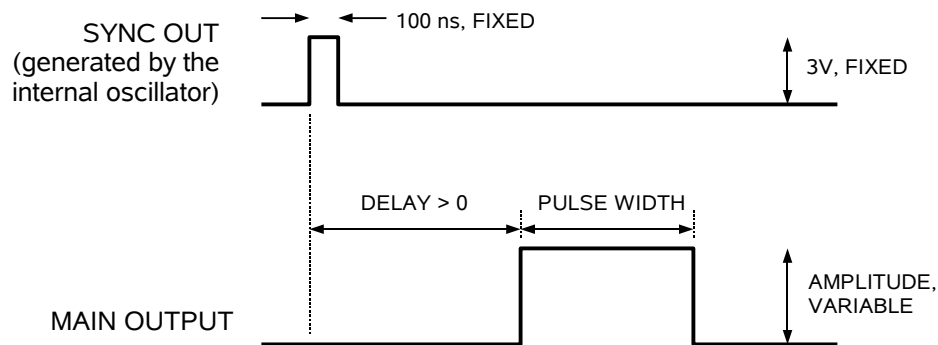

Figure A

If the delay is negative, the order of the SYNC and OUT pulses is reversed:

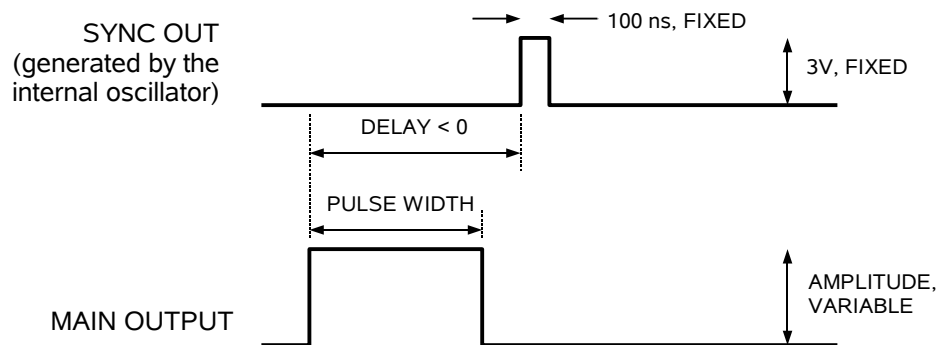

Figure B

The next figure illustrates the relationship between the signal when an external TTL-level trigger is used:

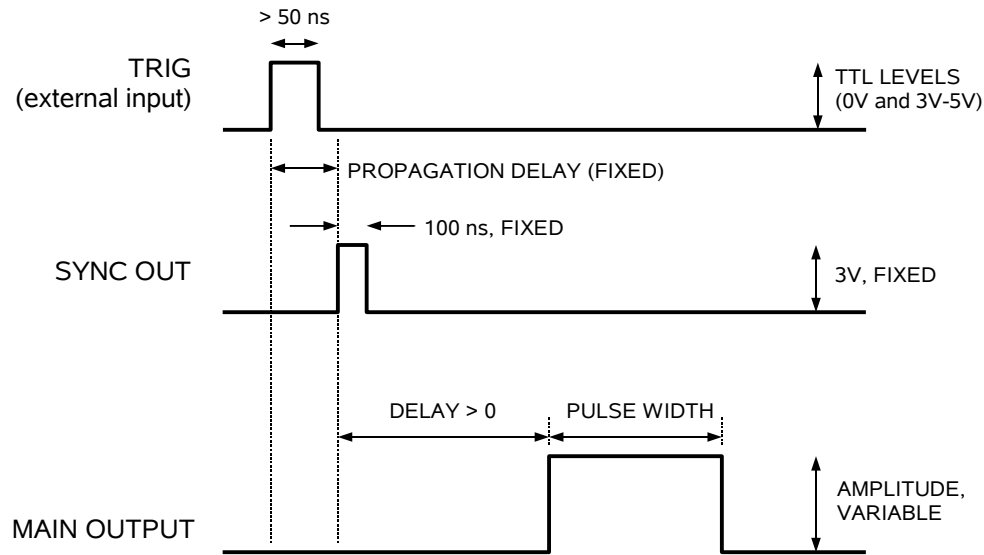

Figure C

As before, if the delay is negative, the order of the SYNC and OUT pulses is reversed.

The delay, pulse width, and frequency (when in the internal mode), of the OUT pulse can be varied with front panel controls or via the GPIB or RS-232 computer interfaces.

TRIGGER MODES

This instrument has four trigger modes:

- Internal Trigger: the instrument controls the trigger frequency, and generates the clock internally.
- External Trigger: the instrument is triggered by an external TTL-level clock on the back-panel TRIG connector.
- Manual Trigger: the instrument is triggered by the front-panel "SINGLE PULSE" pushbutton.
- Hold Trigger: the instrument is set to not trigger at all.

These modes can be selected using the front panel trigger menu, or by using the appropriate programming commands. (See the "Programming Manual for -B Instruments" for more details.)

GATING MODES

Triggering can be suppressed by a TTL-level signal on the rear-panel GATE connector. The instrument can be set to stop triggering when this input high or low, using the front-panel gate menu or the appropriate programming commands. This input can also be set to act synchronously or asynchronously. When set to asynchronous mode, the GATE will disable the output immediately. Output pulses may be truncated. When set to synchronous mode, the output will complete the full pulse width if the output is high, and then stop triggering. No pulses are truncated in this mode.

OPERATIONAL CHECK

This section describes a sequence to confirm the basic operation of the instrument. It should be performed after receiving the instrument. It is a useful learning exercise as well.

Before proceeding with this procedure, finish read this instruction manual thoroughly. Then read the “Local Control” section of the “Programming Manual for -B Instruments” thoroughly. The “Local Control” section describes the front panel controls used in this operational check - in particular, the MOVE, CHANGE, and ADJUST controls.

For the first test, the output module is not used.

1. Connect a cable from the SYNC OUT connector to the TRIG input of an oscilloscope. Connect a 5W (or higher) 50Ω load to the OUT connector on the rear panel of the mainframe and place the scope probe across this load. Set the oscilloscope to trigger externally.

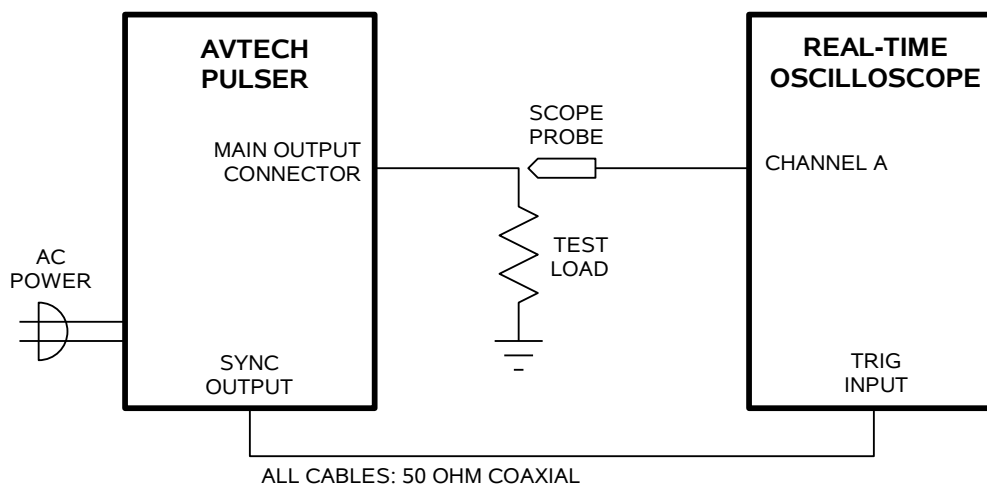

2. Turn on the AVO-6C-B. The main menu will appear on the LCD.
3. To set the AVO-6C-B to trigger from the internal clock at a PRF of 1 kHz:
 - a) The arrow pointer should be pointing at the frequency menu item. If it is not, press the MOVE button until it is.
 - b) Press the CHANGE button. The frequency submenu will appear. Rotate the ADJUST knob until the frequency is set at 1 kHz.
 - c) The arrow pointer should be pointing at the “Internal” choice. If it is not, press MOVE until it is.
 - d) Press CHANGE to return to the main menu.

4. To set the delay to 1 us:

- a) Press the MOVE button until the arrow pointer is pointing at the delay menu item.
- b) Press the CHANGE button. The delay submenu will appear. Rotate the ADJUST knob until the delay is set at 1 us.
- c) The arrow pointer should be pointing at the "Normal" choice. If it is not, press MOVE until it is.
- d) Press CHANGE to return to the main menu.

5. To set the pulse width to 1 us:

- a) Press the MOVE button until the arrow pointer is pointing at the pulse width menu item.
- b) Press the CHANGE button. The pulse width submenu will appear. Rotate the ADJUST knob until the pulse width is set at 1 us.
- c) Press CHANGE to return to the main menu.

6. At this point, nothing should appear on the oscilloscope.

7. To enable the output:

- a) Press the MOVE button until the arrow pointer is pointing at the output menu item.
- b) Press the CHANGE button. The output submenu will appear.
- c) Press MOVE until the arrow pointer is pointing at the "ON" choice.
- d) Press CHANGE to return to the main menu.

8. To change the output amplitude:

- a) Press the MOVE button until the arrow pointer is pointing at the amplitude menu item.
- b) Press the CHANGE button. The amplitude submenu will appear. Rotate the ADJUST knob until the amplitude is set at 250V.
- c) Observe the oscilloscope. You should see 1 us wide, 250V pulses.
- d) Rotate the ADJUST knob. The amplitude as seen on the oscilloscope should vary.
- e) Press CHANGE to return to the main menu.

9. Repeat the last step, but set the amplitude to zero.

10. This completes the first operational check test.

For the second test, the output module is connected.

1. Connect a cable from the SYNC OUT connector to the TRIG input of an oscilloscope. Connect the IN port of the output module to the OUT port on the rear panel of the mainframe using the supplied RG174 cable. Attach the laser diode anode to the output module "OUT" terminal. Connect a Tektronix CT2 or Pearson 2878 current probe (or equivalent) as shown below. Connect the current probe to the oscilloscope. (Some current probes may require a 50 Ohm termination). Set the oscilloscope to trigger externally.

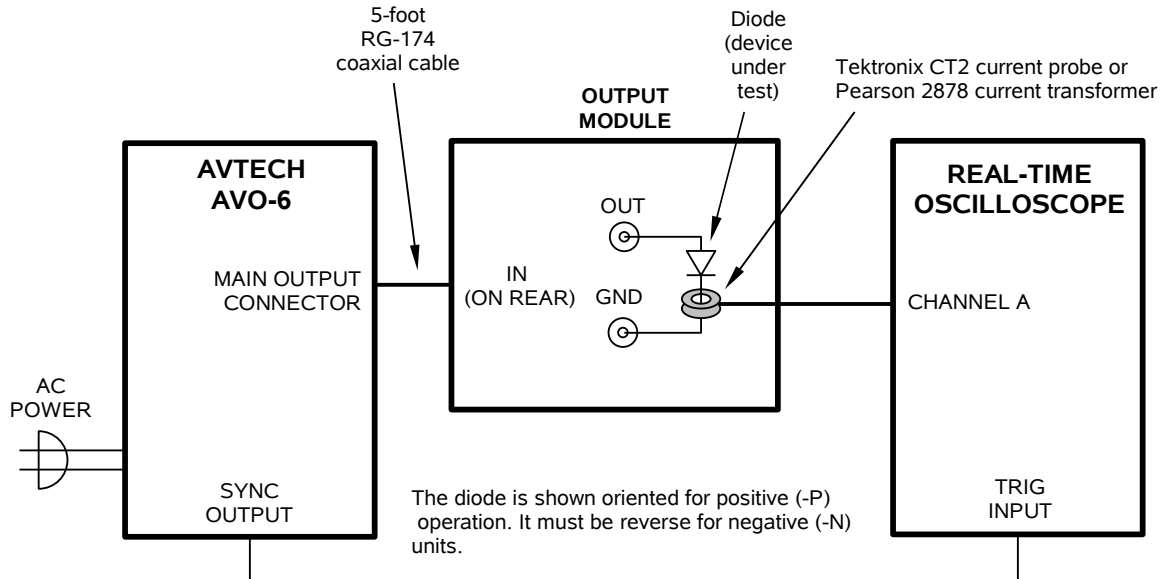

2. Turn on the AVO-6C-B. The main menu will appear on the LCD.
3. To set the AVO-6C-B to trigger from the internal clock at a PRF of 1 kHz:
 - a) The arrow pointer should be pointing at the frequency menu item. If it is not, press the MOVE button until it is.
 - b) Press the CHANGE button. The frequency submenu will appear. Rotate the ADJUST knob until the frequency is set at 1 kHz.
 - c) The arrow pointer should be pointing at the "Internal" choice. If it is not, press MOVE until it is.
 - d) Press CHANGE to return to the main menu.
4. To set the delay to 1 us:
 - a) Press the MOVE button until the arrow pointer is pointing at the delay menu item.
 - b) Press the CHANGE button. The delay submenu will appear. Rotate the ADJUST knob until the delay is set at 1 us.
 - c) The arrow pointer should be pointing at the "Normal" choice. If it is not, press MOVE until it is.

d) Press CHANGE to return to the main menu.

5. To set the pulse width to 1 μ s:

a) Press the MOVE button until the arrow pointer is pointing at the pulse width menu item.

b) Press the CHANGE button. The pulse width submenu will appear. Rotate the ADJUST knob until the pulse width is set at 1 μ s.

c) Press CHANGE to return to the main menu.

6. At this point, nothing should appear on the oscilloscope.

7. To enable the output:

a) Press the MOVE button until the arrow pointer is pointing at the output menu item.

b) Press the CHANGE button. The output submenu will appear.

c) Press MOVE until the arrow pointer is pointing at the "ON" choice.

d) Press CHANGE to return to the main menu.

8. To change the output amplitude:

a) Press the MOVE button until the arrow pointer is pointing at the amplitude menu item.

b) Press the CHANGE button. The amplitude submenu will appear. Rotate the ADJUST knob until the amplitude is set at 250V.

c) Observe the oscilloscope. You should see 1 μ s wide pulses. The voltage across the current probe (Tektronix CT2 or Pearson 2878) should correspond to a measurement of 5 A of current. (A series-connected current-sensing resistor may also be used to measure the current, but this method often produces pronounced overshoot on the rising and falling edges. This is a measurement artefact, and is not present on the actual current waveform. This may be confirmed by using a current probe.)

d) Press CHANGE to return to the main menu.

9. Repeat the last step, but set the amplitude to zero.

10. This completes the operational check.

PROGRAMMING YOUR PULSE GENERATOR

KEY PROGRAMMING COMMANDS

The “Programming Manual for -B Instruments” describes in detail how to connect the pulse generator to your computer, and the programming commands themselves. A large number of commands are available; however, normally you will only need a few of these. Here is a basic sample sequence of commands that might be sent to the instrument after power-up:

| | |
|-------------------------|---------------------------------|
| *rst | (resets the instrument) |
| trigger:source internal | (selects internal triggering) |
| frequency 1000 Hz | (sets the frequency to 1000 Hz) |
| pulse:width 1 us | (sets the pulse width to 1 us) |
| pulse:delay 2 us | (sets the delay to 2 us) |
| volt 200 | (sets the amplitude to 200 V) |
| output on | (turns on the output) |

For triggering a single event, this sequence would be more appropriate:

| | |
|--------------------------|---|
| *rst | (resets the instrument) |
| trigger:source hold | (turns off all triggering) |
| pulse:width 1 us | (sets the pulse width to 1 us) |
| output on | (turns on the output) |
| volt 200 | (sets the amplitude to 200 V) |
| trigger:source immediate | (generates a single non-repetitive trigger event) |
| trigger:source hold | (turns off all triggering) |
| output off | (turns off the output) |

To set the instrument to trigger from an external TTL input:

| | |
|-------------------------|--------------------------------|
| *rst | (resets the instrument) |
| trigger:source external | (selects external triggering) |
| pulse:width 1 us | (sets the pulse width to 1 us) |
| pulse:delay 2 us | (sets the delay to 2 us) |
| volt 200 | (sets the amplitude to 200 V) |
| output on | (turns on the output) |

These commands will satisfy 90% of your programming needs.

ALL PROGRAMMING COMMANDS

For more advanced programmers, a complete list of the available commands is given below. These commands are described in detail in the “Programming Manual for -B Instruments”. (Note: this manual also includes some commands that are not implemented in this instrument. They can be ignored.)

| <u>Keyword</u> | <u>Parameter</u> | <u>Notes</u> |
|----------------|----------------------------|----------------------------------|
| LOCAL | | |
| OUTPut: | | |
| :[STATe] | <boolean value> | |
| :PROTection | | |
| :TRIPped? | | [query only] |
| REMOTE | | |
| [SOURce]: | | |
| :FREQuency | | |
| [:CW FIXed] | <numeric value> | |
| [SOURce]: | | |
| :PULSe | | |
| :PERiod | <numeric value> | |
| :WIDTh | <numeric value> | |
| :DCYClE | <numeric value> | |
| :HOLD | WIDTh DCYClE | |
| :DELay | <numeric value> | |
| :GATE | | |
| :TYPE | ASYNc SYNc | |
| :LEVel | High Low | |
| [SOURce]: | | |
| :VOLTage | | |
| [:LEVel] | | |
| [:IMMediate] | | |
| [:AMPLitude] | <numeric value> EXTernal | |
| :PROTection | | |
| :TRIPped? | | [query only] |
| STATUS: | | |
| :OPERation | | |
| :[EVENT]? | | [query only, always returns "0"] |
| :CONDition? | | [query only, always returns "0"] |
| :ENABle | <numeric value> | [implemented but not useful] |
| :QUESTionable | | |
| :[EVENT]? | | [query only, always returns "0"] |
| :CONDition? | | [query only, always returns "0"] |
| :ENABle | <numeric value> | [implemented but not useful] |
| SYSTEM: | | |
| :COMMunicate | | |
| :GPIB | | |
| :ADDReSS | <numeric value> | |
| :SERial | | |
| :CONTRol | | |
| :RTS | ON IBFull RFR | |
| :[RECEive] | | |
| :BAUD | 1200 2400 4800 9600 | |
| :BITS | 7 8 | |
| :ECHO | <boolean value> | |
| :PARity | | |
| :[TYPE] | EVEN ODD NONE | |

| | | | |
|-----------|--------|---|-----------------|
| | :SBITS | 1 2 | |
| :ERRor | | | |
| :[NEXT]? | | | [query only] |
| :COUNT? | | | [query only] |
| :VERSion? | | | [query only] |
| TRIGger: | | | |
| :SOURce | | INTernal EXTernal MANual HOLD IMMEDIATE | [no query form] |
| *CLS | | | |
| *ESE | | <numeric value> | |
| *ESR? | | | [query only] |
| *IDN? | | | [query only] |
| *OPC | | | |
| *SAV | | 0 1 2 3 | [no query form] |
| *RCL | | 0 1 2 3 | [no query form] |
| *RST | | | [no query form] |
| *SRE | | <numeric value> | |
| *STB? | | | [query only] |
| *TST? | | | [query only] |
| *WAI | | | [no query form] |

MECHANICAL INFORMATION

TOP COVER REMOVAL

If necessary, the interior of the instrument may be accessed by removing the four Phillips screws on the top panel. With the four screws removed, the top cover may be slid back (and off).

Always disconnect the power cord before opening the instrument.

There are no user-adjustable internal circuits. For repairs other than fuse replacement, please contact Avtech (info@avtechpulse.com) to arrange for the instrument to be returned to the factory for repair.

 Caution: High voltages are present inside the instrument during normal operation. Do not operate the instrument with the cover removed.

RACK MOUNTING

A rack mounting kit is available. The -R5 rack mount kit may be installed after first removing the one Phillips screw on the side panel adjacent to the front handle.

ELECTROMAGNETIC INTERFERENCE

To prevent electromagnetic interference with other equipment, all used outputs should be connected to shielded 50Ω loads using shielded 50Ω coaxial cables. Unused outputs should be terminated with shielded 50Ω coaxial terminators or with shielded coaxial dust caps, to prevent unintentional electromagnetic radiation. All cords and cables should be less than 3m in length.

MAINTENANCE

REGULAR MAINTENANCE

This instrument does not require any regular maintenance.

On occasion, one or more of the four rear-panel fuses may require replacement. All fuses can be accessed from the rear panel. See the “FUSES” section for details.

CLEANING

If desired, the interior of the instrument may be cleaned using compressed air to dislodge any accumulated dust. (See the “TOP COVER REMOVAL” section for instructions on accessing the interior.) No other cleaning is recommended.

WIRING DIAGRAMS

WIRING OF AC POWER

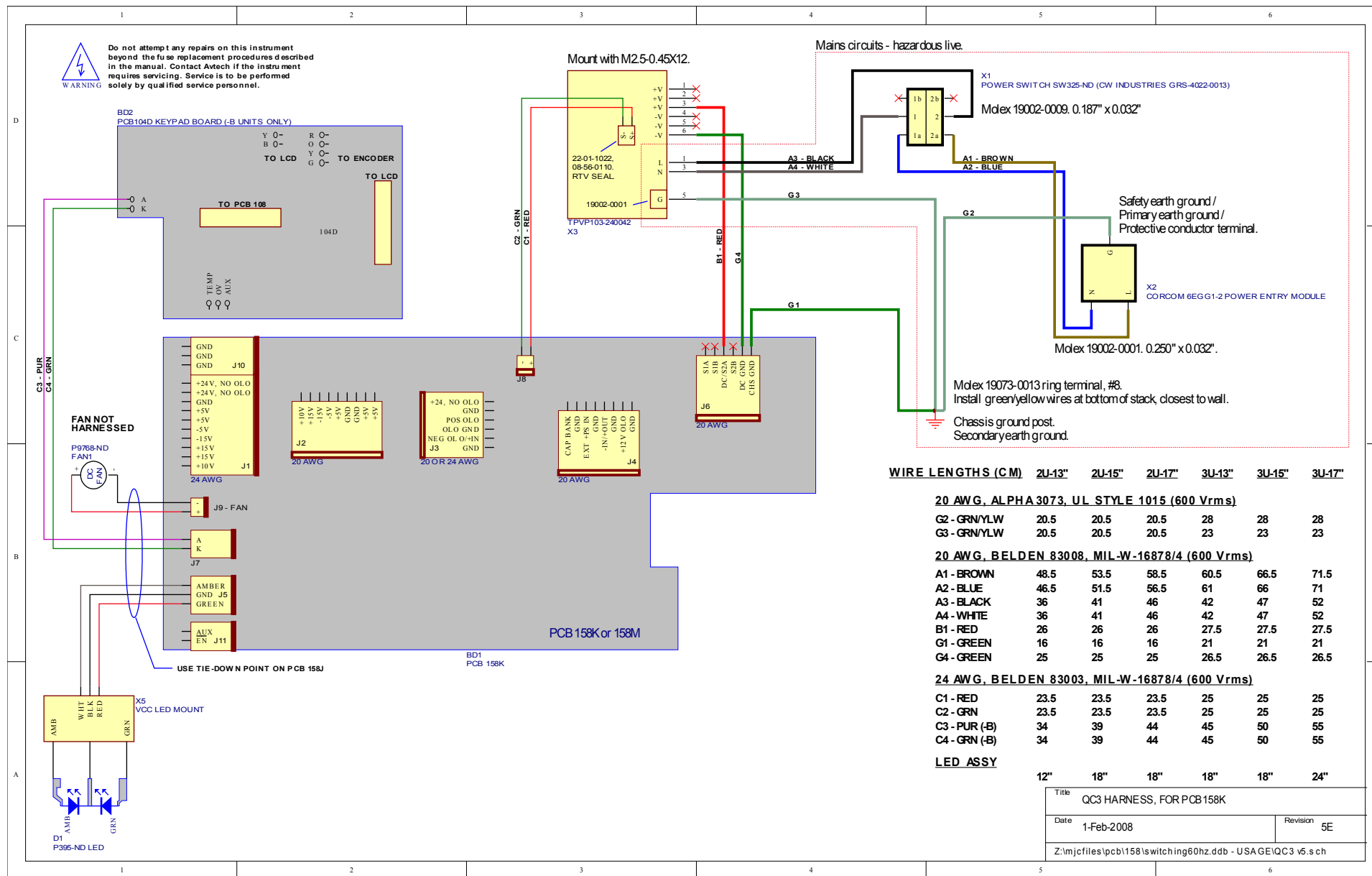

PCB 158M - LOW VOLTAGE POWER SUPPLY, 1/3

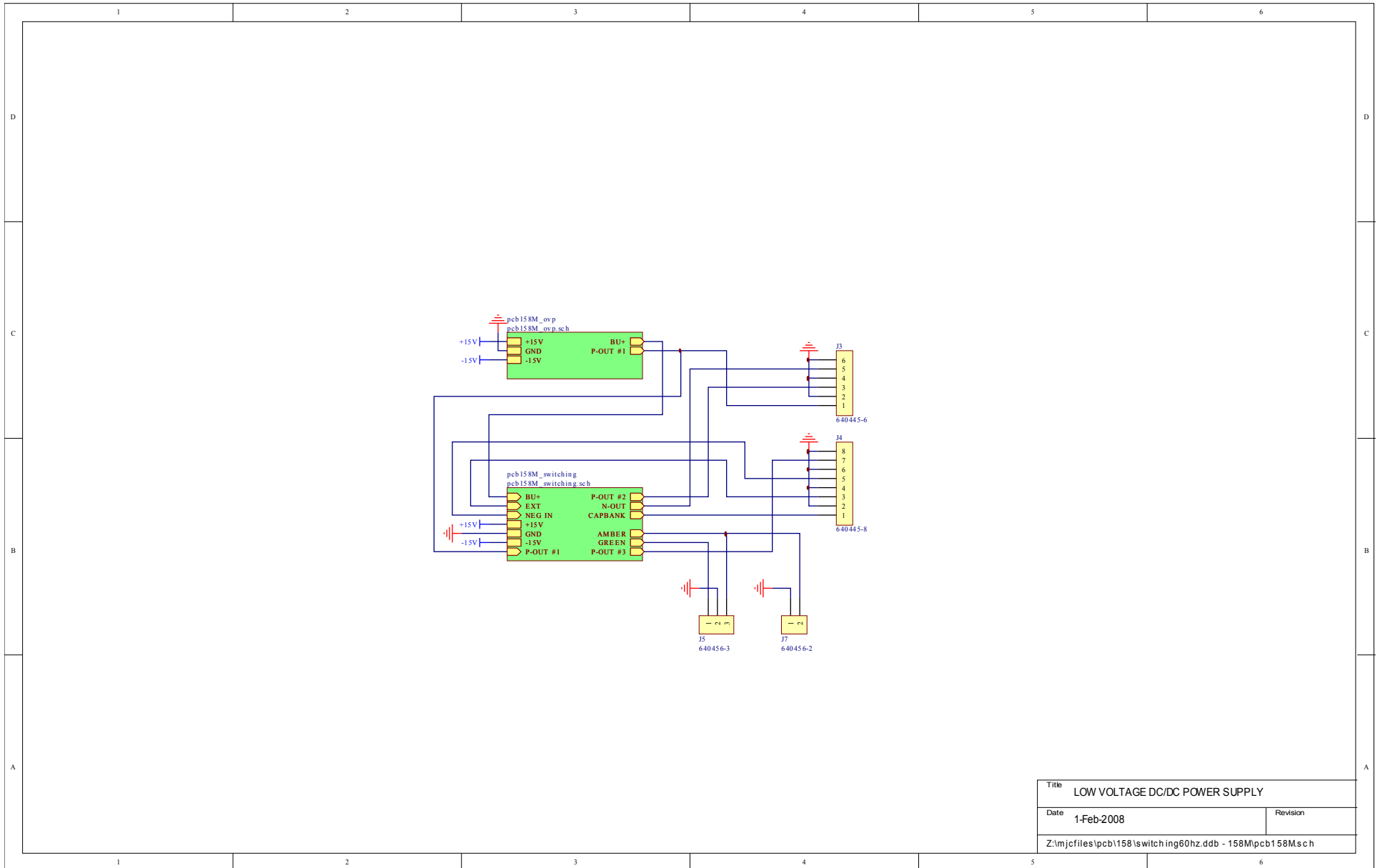

| | | |
|--|------------|--------------------------------|
| Title | | LOW VOLTAGE DC/DC POWER SUPPLY |
| Date | 1-Feb-2008 | Revision |
| Z:\mjc\files\pcb158\switching60hz.ddb - 158M\pcb158M.sch | | |

PCB 158M - LOW VOLTAGE POWER SUPPLY, 2/3

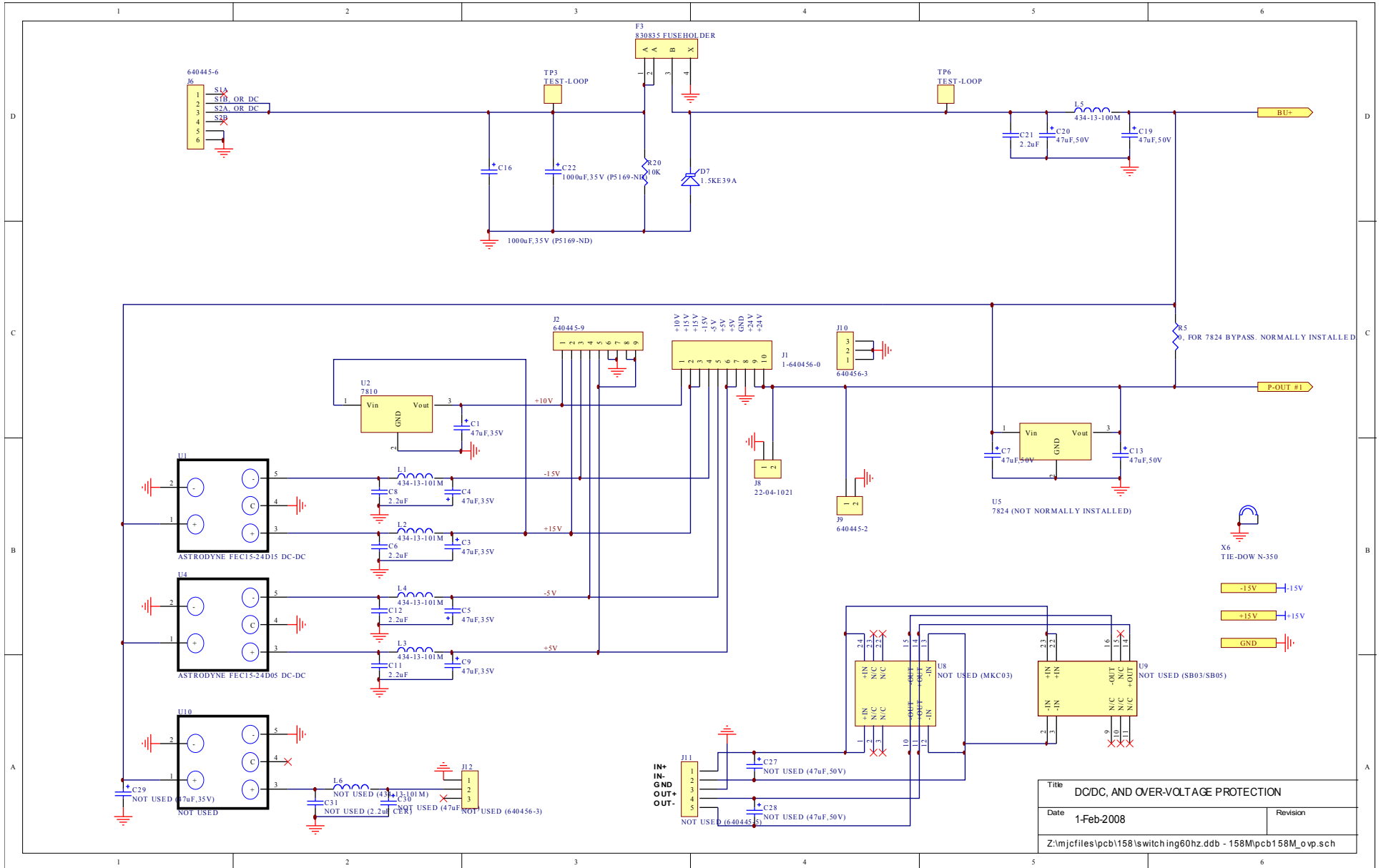

PCB 158M - LOW VOLTAGE POWER SUPPLY, 3/3

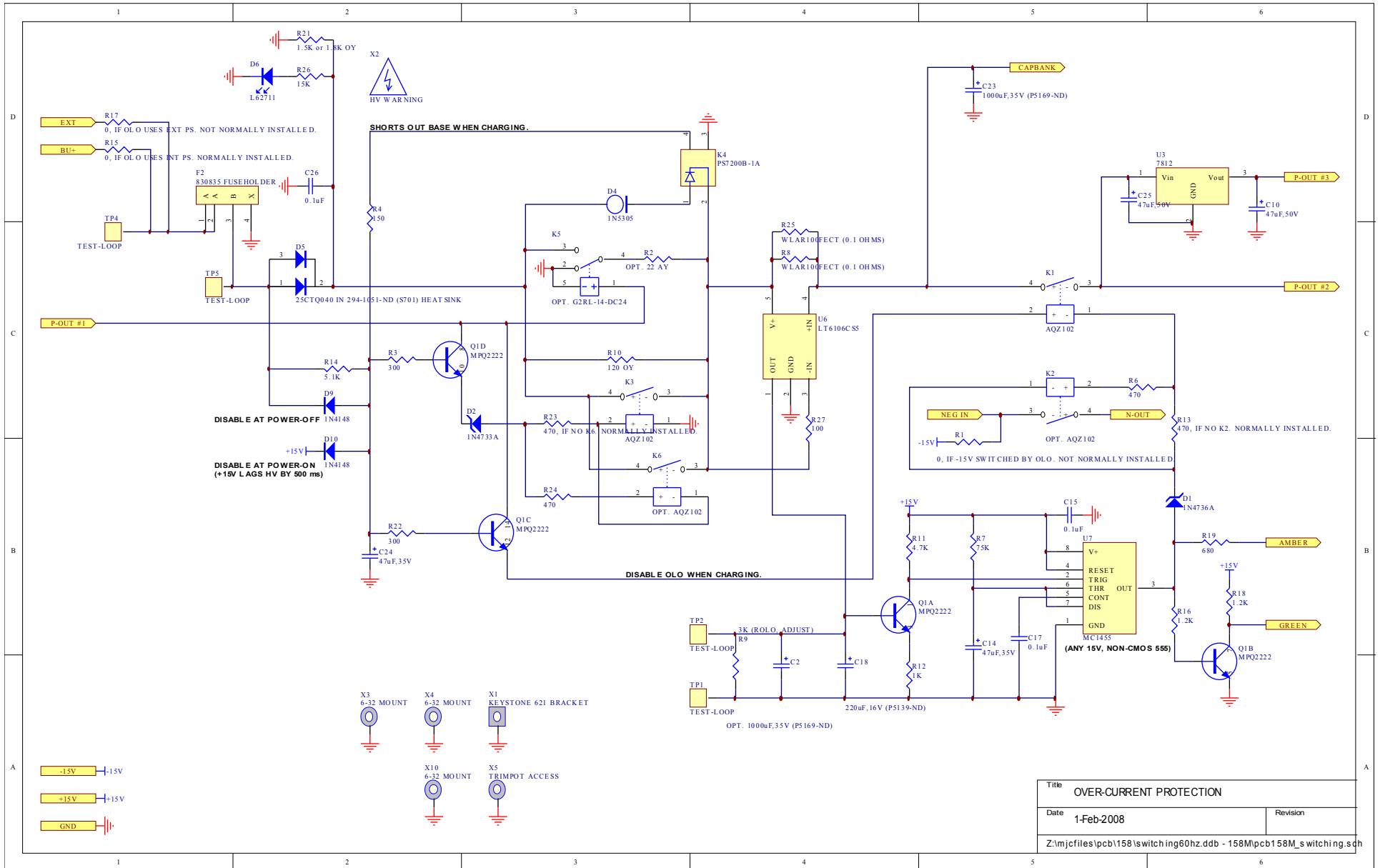

PCB 157C - HIGH VOLTAGE DISCHARGE BOARD

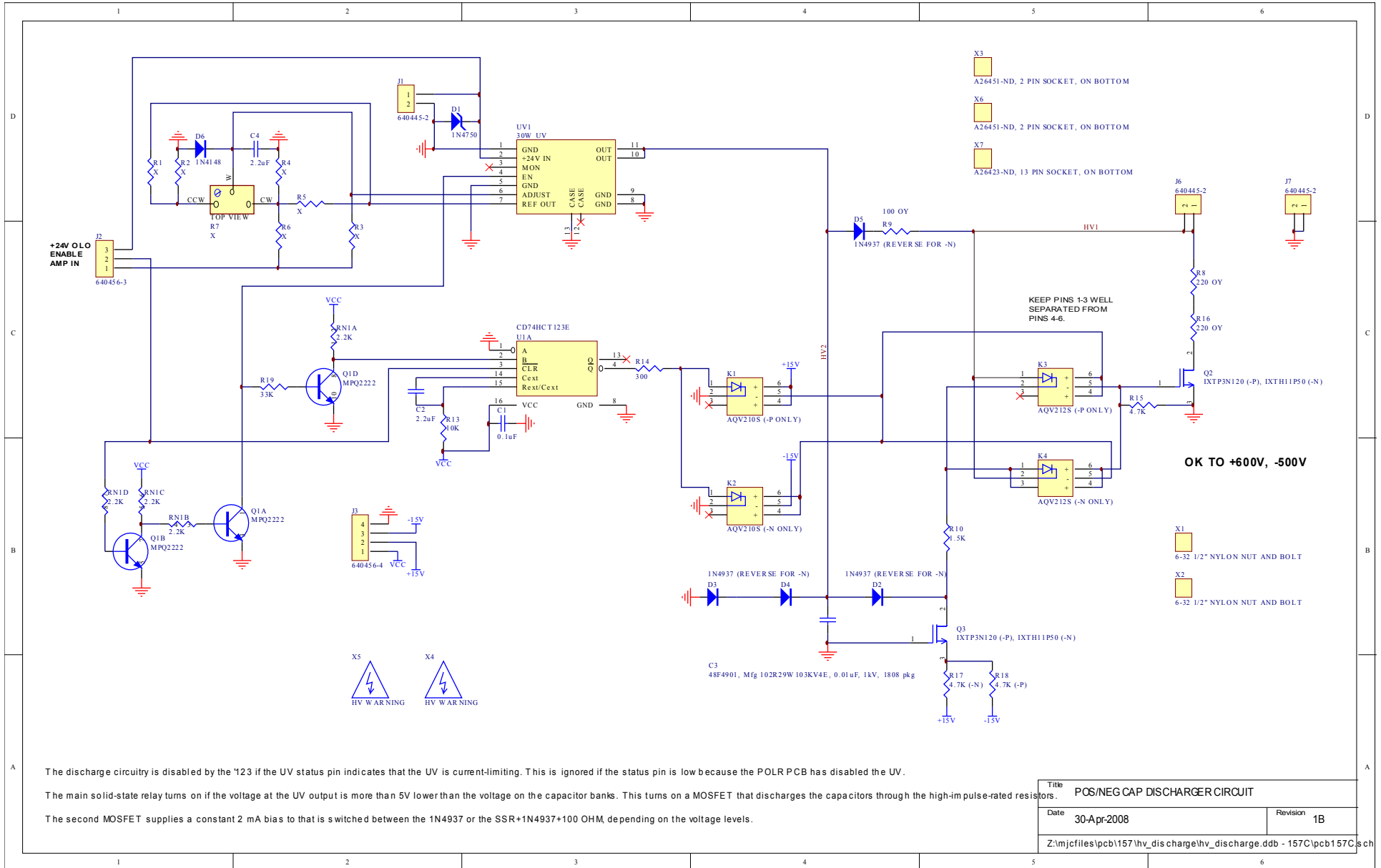

PCB 183A-S AND 183A-P CAPACITOR BANKS

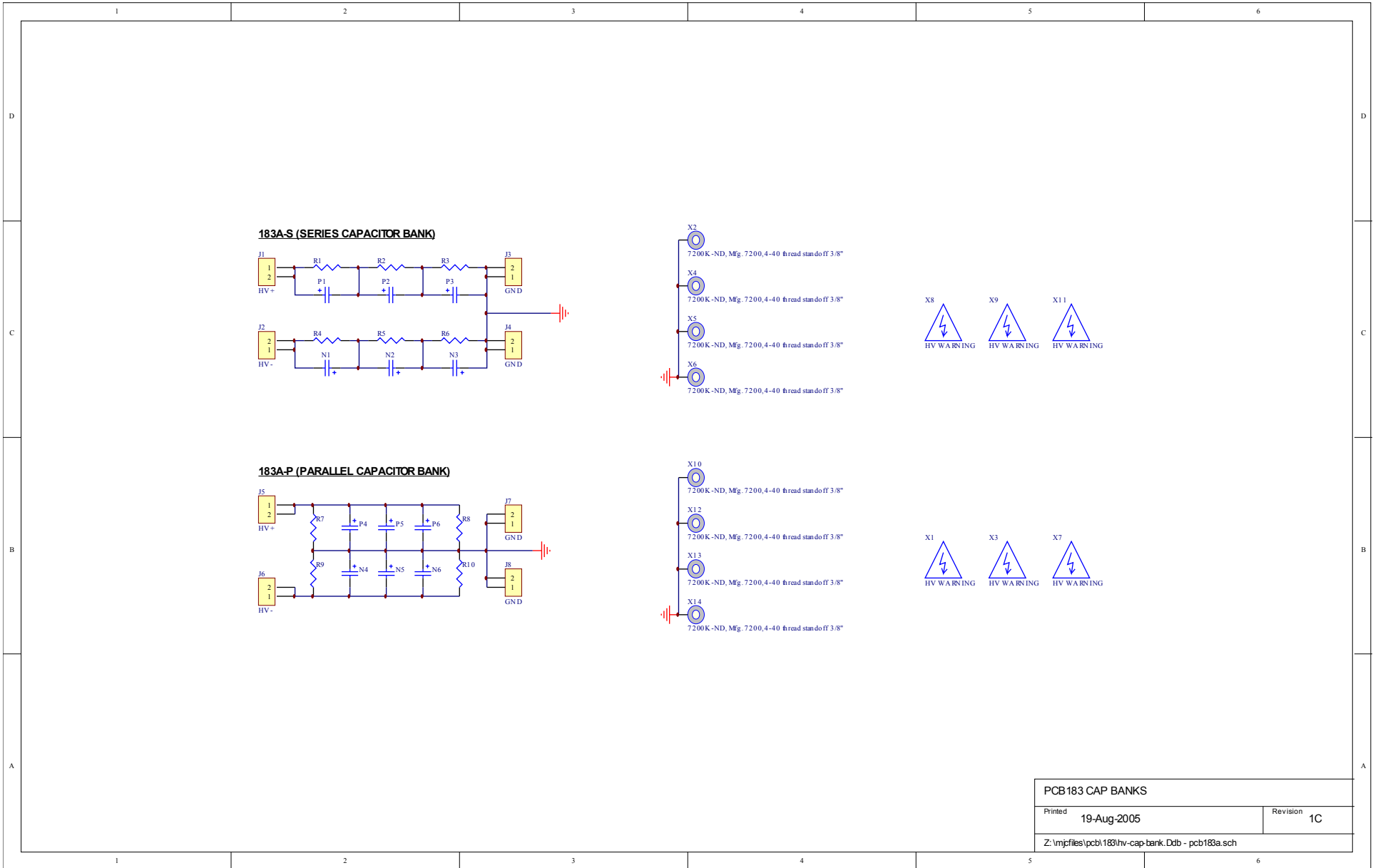

| | |
|---|-------------|
| PCB 183 CAP BANKS | |
| Printed 19-Aug-2005 | Revision 1C |
| Z:\mjrfiles\pcb\183\hv-cap-bank.Ddb - pcb183a.sch | |

PCB 156B – POLARITY SWITCHING CONTROL (-PN UNITS)

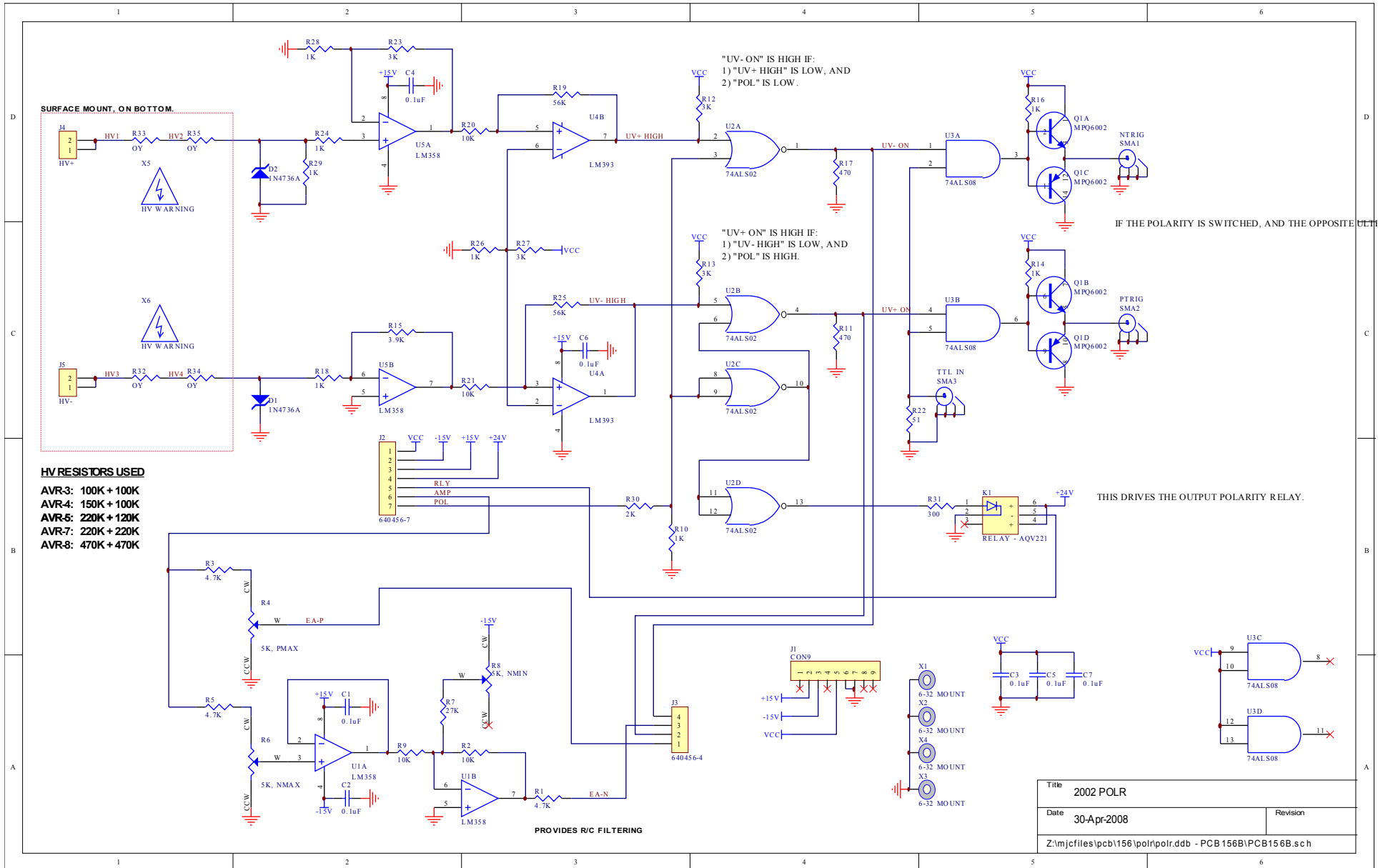

PCB 104D - KEYPAD / DISPLAY BOARD, 1/3

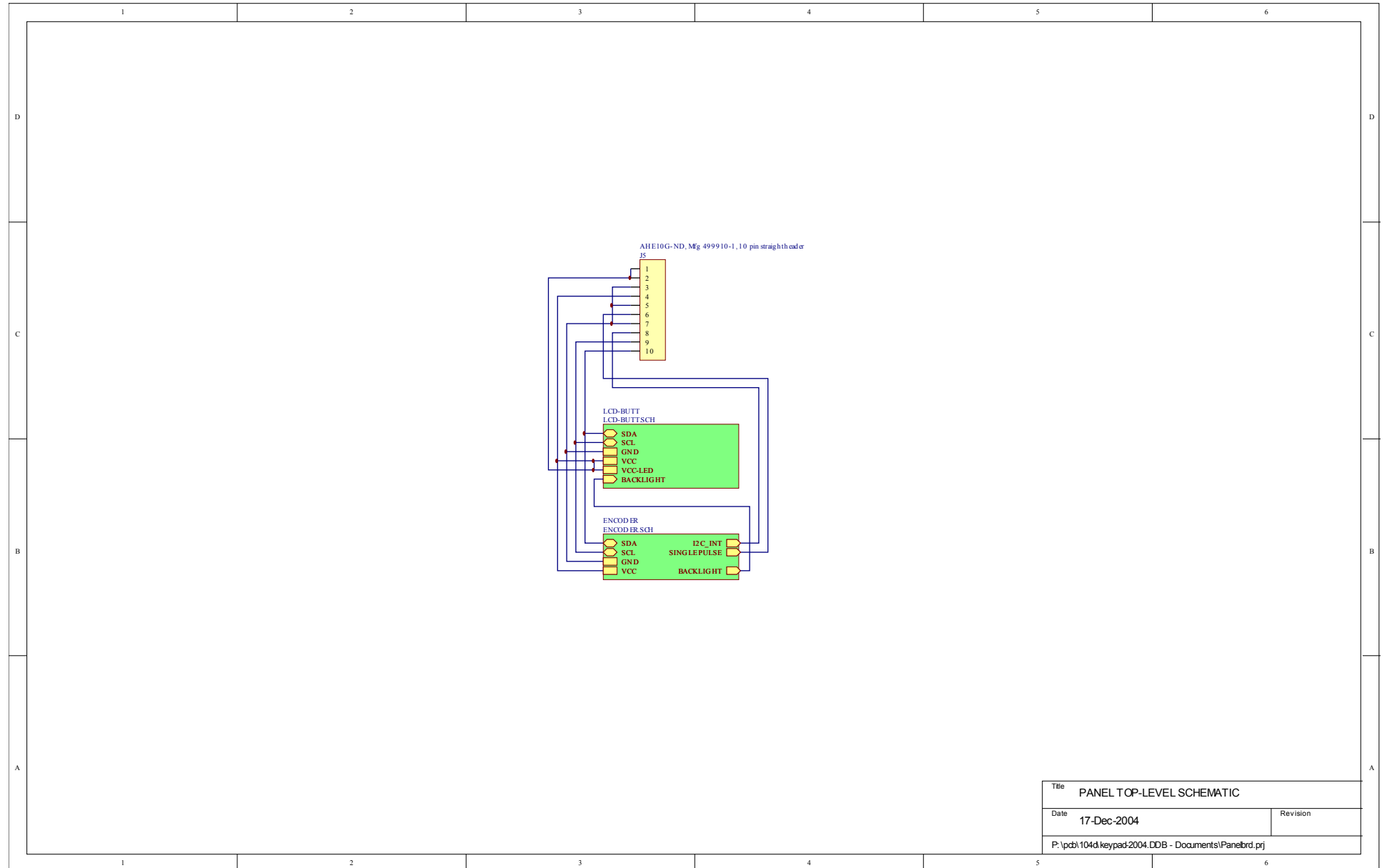

PCB 104D - KEYPAD / DISPLAY BOARD, 2/3

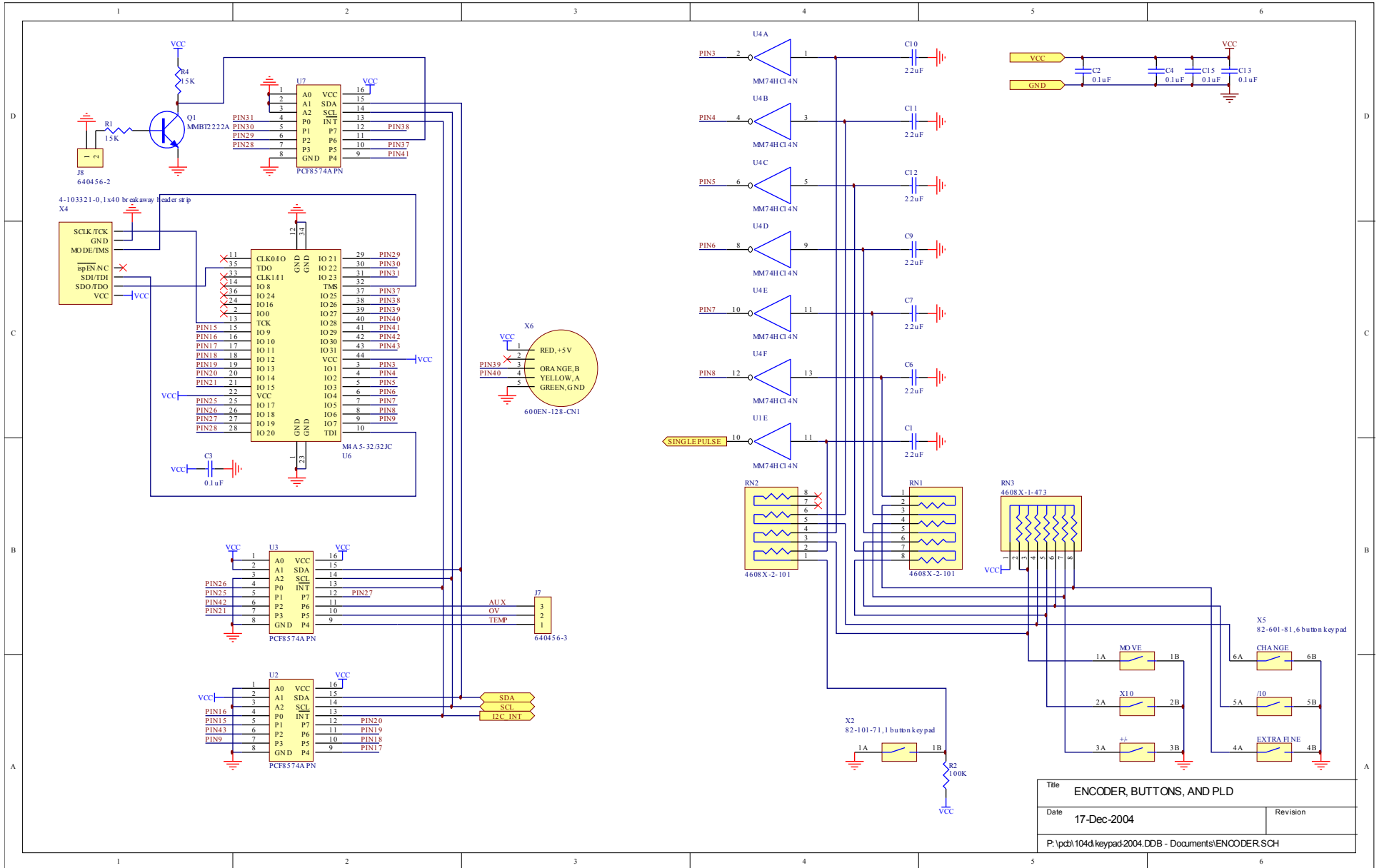

| | | |
|---|-------------|---------------------------|
| Title | | ENCODER, BUTTONS, AND PLD |
| Date | 17-Dec-2004 | Revision |
| P:\pcb\104d\keypad\2004.DDB - Documents\ENCODER.SCH | | |

PCB 104D - KEYPAD / DISPLAY BOARD, 3/3

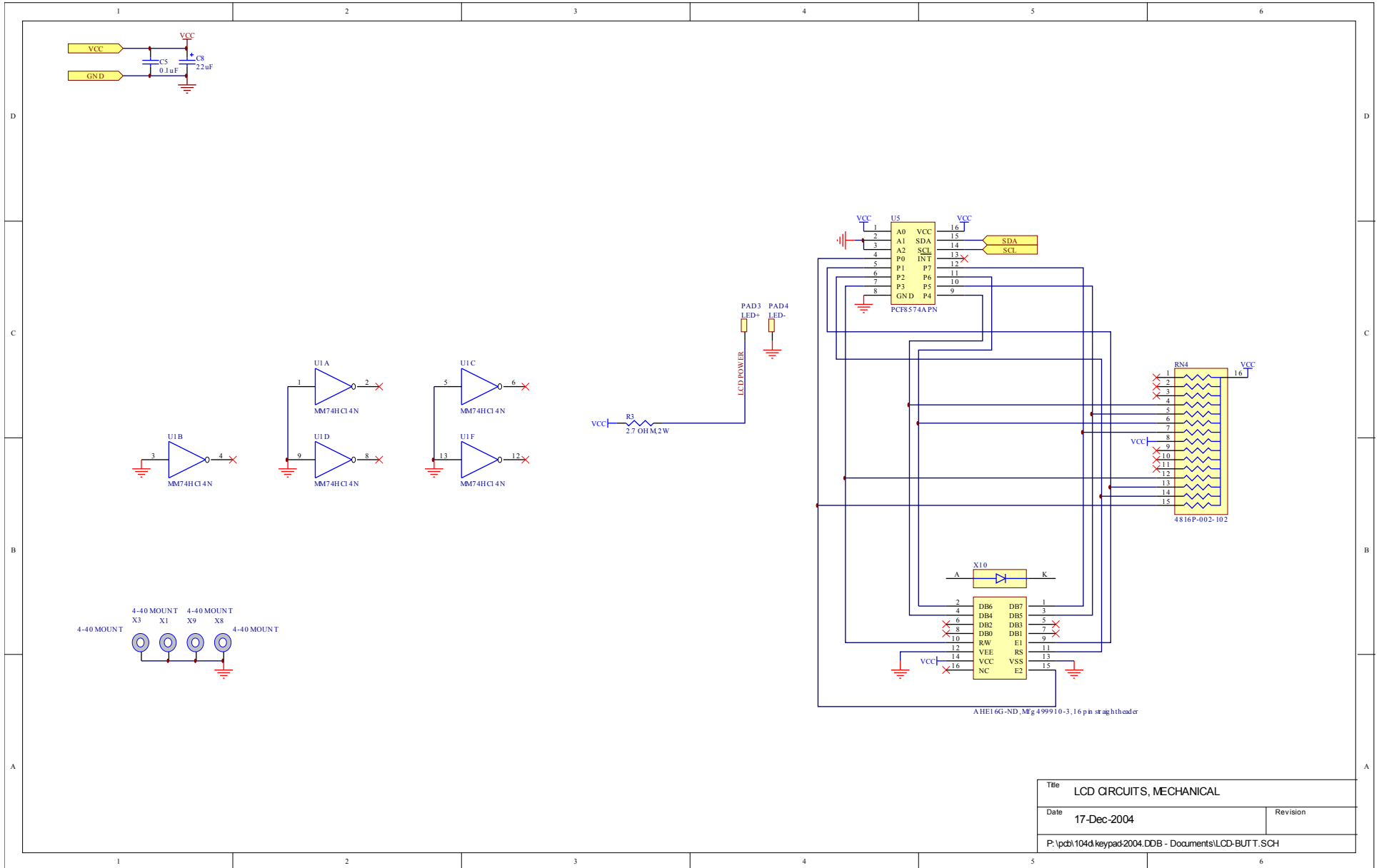

| | | | |
|--|-------------|--------------------------|--|
| Title | | LCD CIRCUITS, MECHANICAL | |
| Date | 17-Dec-2004 | Revision | |
| P:\pcb\104d\keypad-2004.DDB - Documents\LCD-BUTT.SCH | | | |

MAIN WIRING (-PN UNITS)

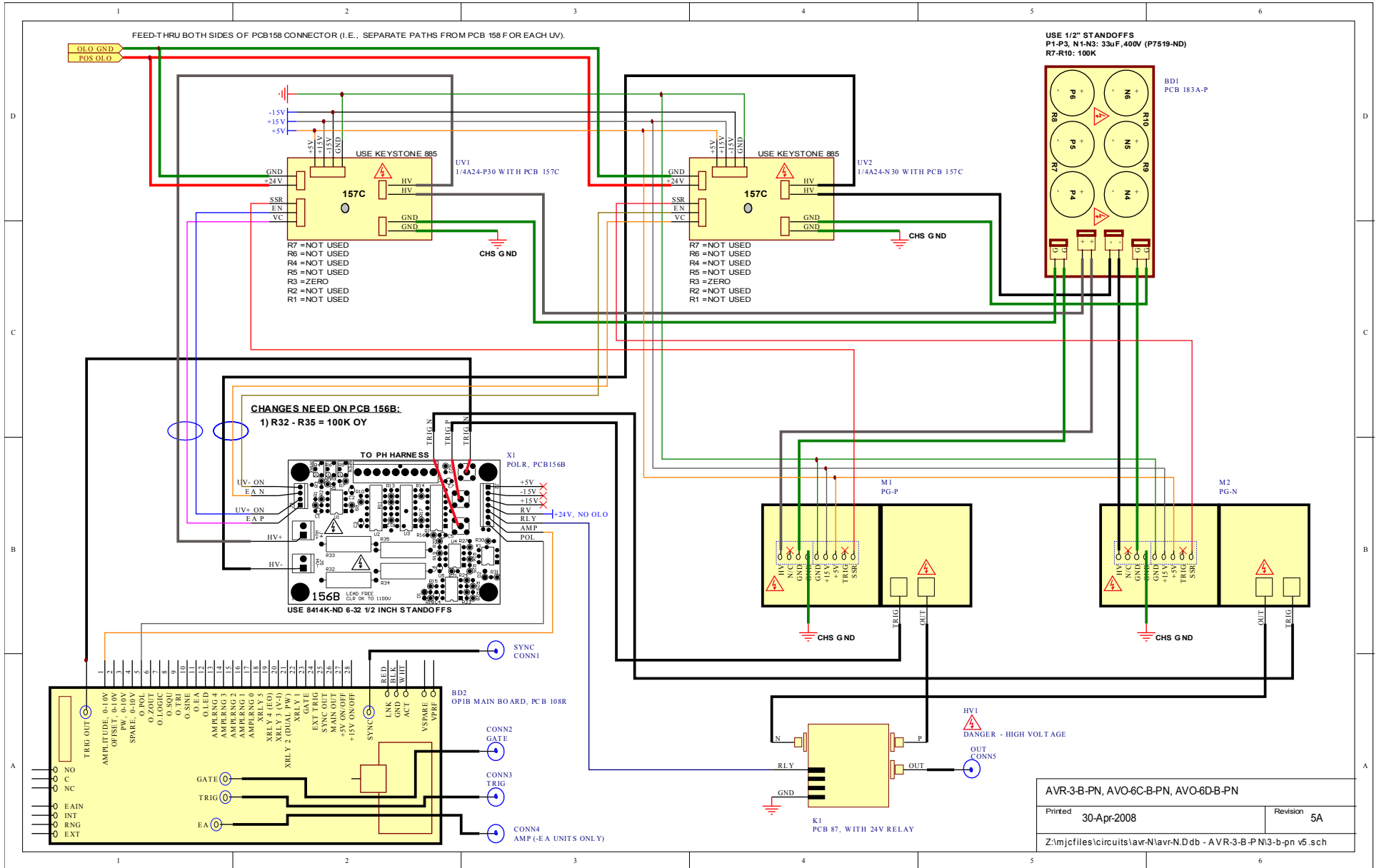

| | |
|---|-------------|
| AVR-3-B-PN, AVO-6C-B-PN, AVO-6D-B-PN | |
| Printed 30-Apr-2008 | Revision 5A |
| Z:\mjc\files\circuits\avr-N\avr-N.Ddb - AVR-3-B-PN3-b-pn v5.sch | |

PERFORMANCE CHECK SHEET